

EXPLODED

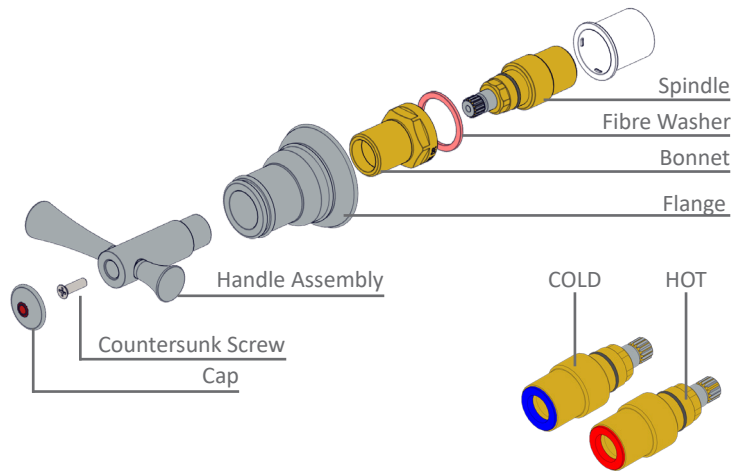

ADJUSTMENT RANGE

**134-0600 -
Wall Top Assembly:**
Min: 0mm
Max: 15mm

**134-0670 -
Wall Top Assembly Ext'd 15mm:**
Min: 15mm
Max: 30mm

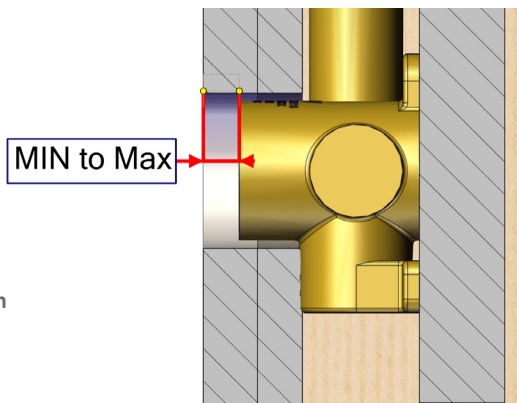

1

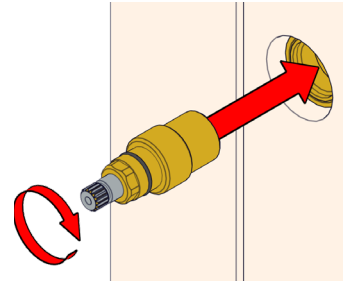

Screw Cartridge Body into recess till Cartridge Seat meets a physical stop.

Do not over tighten.

2

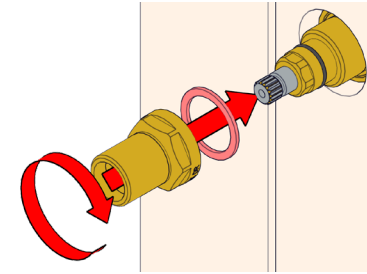

Fit Fibre Washer around the Spindle and then firmly fasten the Bonnet onto the Spindle using a spanner.

3

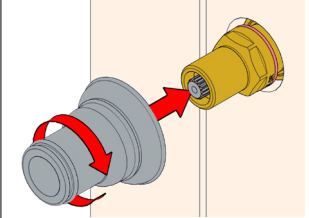

Screw Flange to the Bonnet until flush with wall.

4

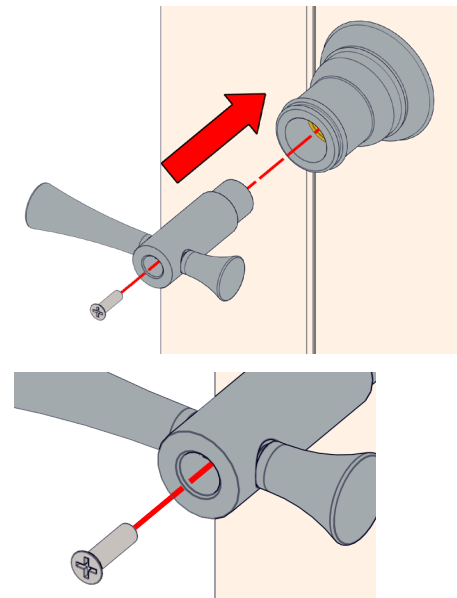

Fit Handle Assembly over spline. Ensuring Handles are level.

Fix to cartridge using supplied countersunk screws.

5

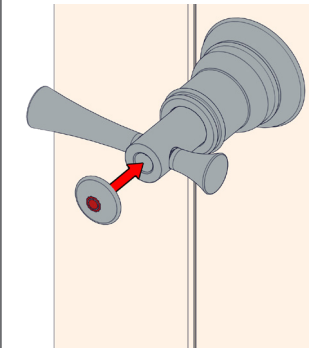

Push temperature indicator caps onto handles as shown.



recommended working pressure

150-500kPa

maximum hot water temperature



75 degrees

NOTE:

- If the pressure exceeds or is likely to exceed 550kpa, an approved pressure limiting device must be installed.
- Flush out all pipe work prior to installation.
- If the water temperature exceeds 75°C, an approved tempering valve must be fitted.
- Installation should comply with Australian standard AS3500.1 or relevant local authority requirements. Showers may not be suitable for use within:
 - Gravity-fed water systems

- Some instantaneous hot water systems; or
 - Pressure supply less than 150kPa;
- NOTE: The 500kPa maximum water supply pressure does not apply to fire service outlets.

Failure to comply with the above may void all warranties.

WARRANTY:

Please refer to the full warranty statement enclosed with the product before installing.

MAINTENANCE AND CARE:

- Chrome plated surfaces should be cleaned with mild liquid detergent or soap and water.
- Do not use cream cleaners or citrus based cleaning products, as they are abrasive.
- Use of unsuitable cleaning agents may damage the surface. Any damage caused in this way will not be covered by warranty.

DISCLAIMER:

While we aim to ensure the specifications shown are correct at the time of printing, we reserve the right to make modifications without prior notice. Always use the physical product measurements for mark-ups and roughing-in as the line drawing shown may differ from the actual product over time.

*All measurements are shown in millimeters.